

# DENALI™

LAH.00.10700.B

**FENDER LIGHT MOUNT**  
DENALI DM & D2 LIGHT PODS

## Thank you for choosing DENALI

We know you would rather be riding your bike than wrenching on it, so we go the extra mile to make sure our instructions are clear and as easy to understand as possible. If you have any questions, comments, or suggestions don't hesitate to give our gear experts a call at 855.255.5550 or visit [DenaliElectronics.com/instructions](http://DenaliElectronics.com/instructions).

## Please Read Before Installing

DENALI products should always be installed by a qualified motorcycle technician. If you are unsure of your ability to properly install a product, please have the product installed by your local motorcycle dealer. DENALI takes no responsibility for damages caused by improper installation. **Caution:** When installing electronics is it extremely important to pay close attention to how wires are routed, especially when mounting products to the front fender, front forks, or fairing of your motorcycle. Always be sure to turn the handlebars fully left, fully right, and fully compress the suspension to ensure the wires will not bind and have enough slack for your motorcycle to operate properly.

## Installation Tips

We strongly recommend using medium strength liquid thread locker on all screws, nuts, and bolts. It is also important to ensure that all hardware is tightened to the proper torque specifications as listed in your owner's manual. For included accessory hardware please refer to the default torque specifications provided below. Inspect all hardware after the first 30 miles to ensure proper torque specifications are maintained.

Bolt Size	in-lbs	ft-lbs	Nm
M3	10.0 in-lbs	-	1.0 Nm
M4	23.0 in-lbs	-	2.5 Nm
M5	44.5 in-lbs	3.5 ft-lbs	5.0 Nm
M6	78.0 in-lbs	6.5 ft-lbs	9.0 Nm
M8	-	13.5 ft-lbs	18.0 Nm
M10	-	30.0 ft-lbs	41.0 Nm
M12	-	52.0 ft-lbs	71.0 Nm

## Hardware Sizing Guide

Not sure what size bolt you have? Use this ruler to measure screws, bolts, spacers, etc. Remember, the length of a screw or bolt is measured from the start of the "mounting surface" to the end of the screw, so only include the screw head when measuring countersunk screws.

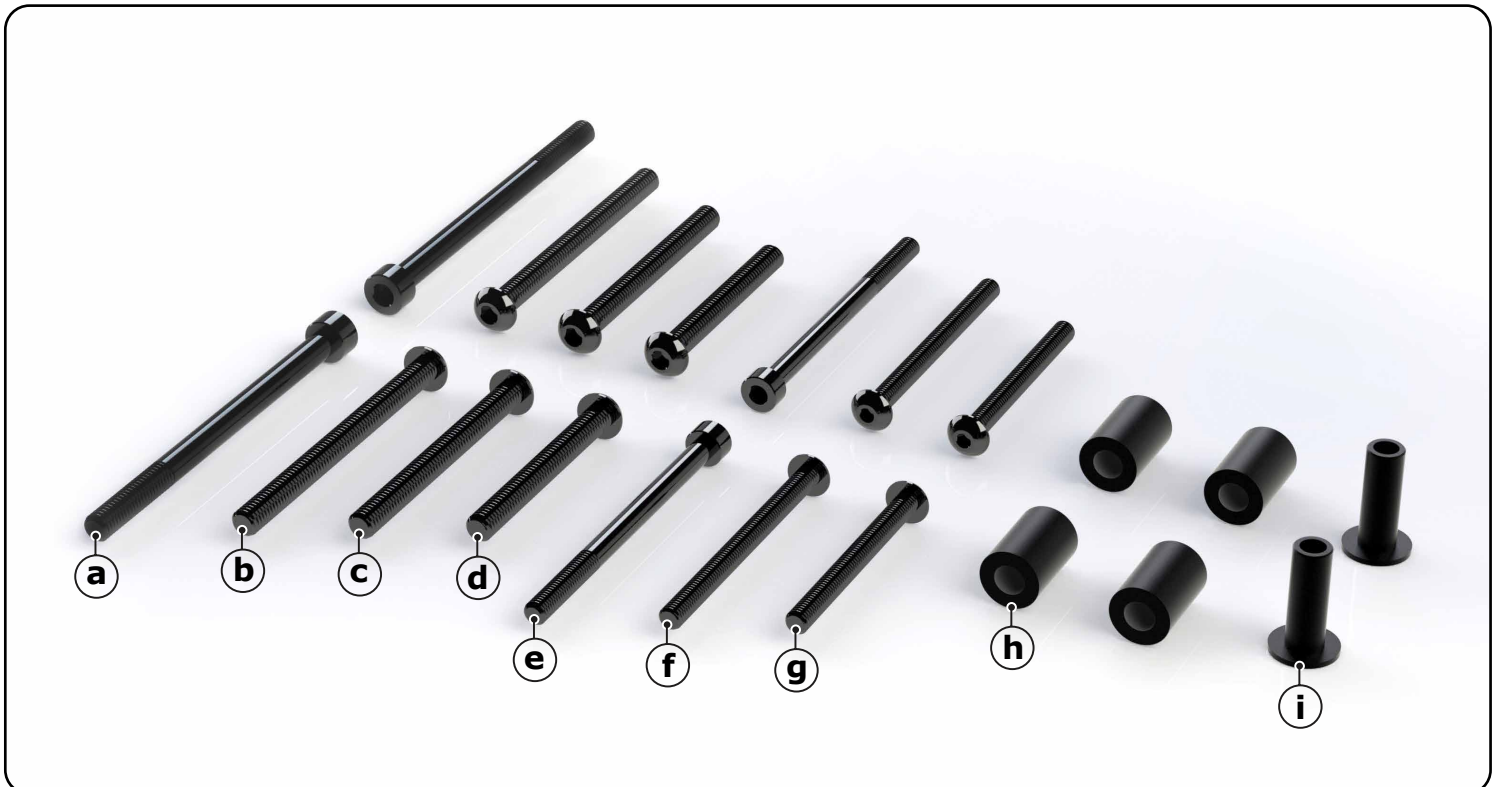
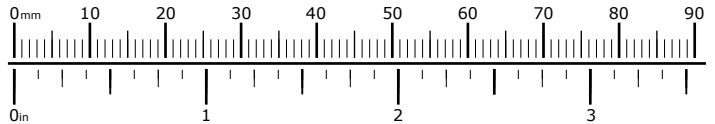

## Kit Contents

- (a) M6x85 DIN 912.....Qty 2
- (b) M6x70 ISO 7380.....Qty 2
- (c) M6x60 ISO 7380.....Qty 2
- (d) M6x50 ISO 7380.....Qty 2
- (e) M5x70 DIN 912.....Qty 2
- (f) M5x60 ISO 7380.....Qty 2
- (g) M6x50 ISO 7380.....Qty 2
- (h) OD:13mm ID:6mm L:19mm..Qty 4
- (i) 6mm to 5mm Bushing.....Qty 2

## Tools Required

- 5mm Allen Key
- 4mm Allen Key
- 3mm Allen Key
- 10mm Wrench (x2)

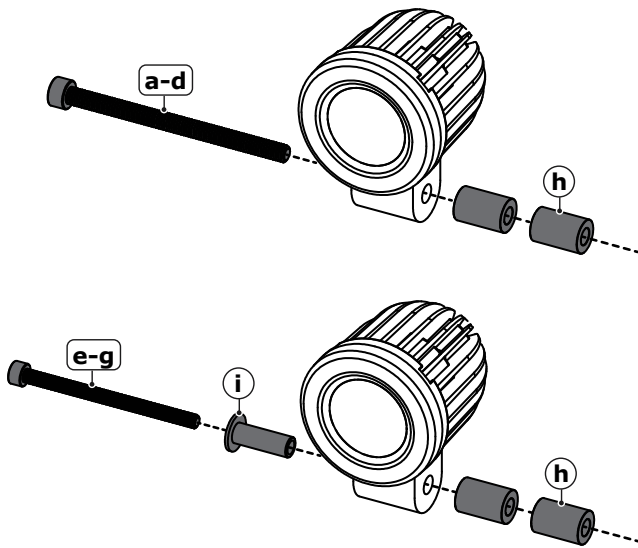
**FIGURE 2**

### Selecting Your Hardware (Denali D2)

**Step One:** Remove the OEM bolt from one side of the fender. Determine if the bolt is M5 or M6.

**Step Two:** Determine if one or two of the spacers (h) will be necessary to offset the D2 pod from the fender for clearance.

**Step Three:** To insure optimal thread engagement, select a bolt (a-g) that protrudes past the spacer leaving the same amount of thread exposed as the bolt

previously removed.

**Note:** When using M5 hardware (e-g) with the D2 pod use the bushing (i) to decrease the hole diameter in the pod hinge. You may find it necessary to press fit the bushing (i) into place. Use a vise or rubber mallet to fully seat the bushing in the light pod.

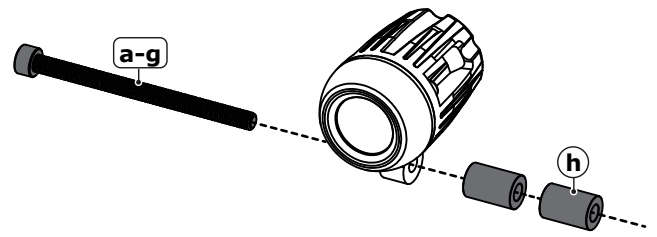
**FIGURE 3**

### Selecting Your Hardware (Denali DM)

**Step One:** Remove the OEM bolt from one side of the fender. Determine if the bolt is M5 or M6.

**Step Two:** Determine if one or two of the spacers (h) will be necessary to offset the DM pod from the fender for clearance.

**Step Three:** For optimal thread engagement, select a bolt (a-g) that protrudes past the spacer leaving the same amount of thread exposed as the bolt

previously removed.

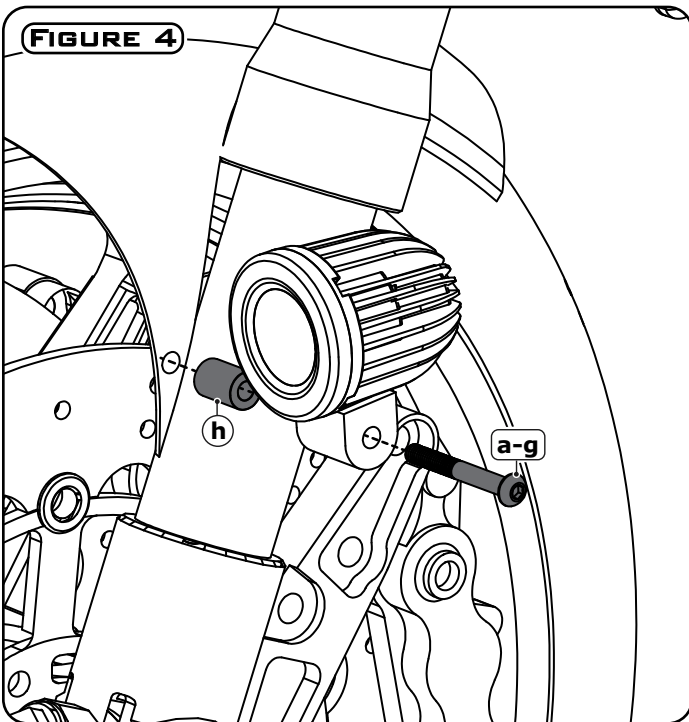
**FIGURE 4**

### Mounting The Lights

**Step Four:** Once the proper hardware has been selected, bolt the light pod and spacer directly to the fender mounting point.

**Step Five:** Repeat steps on opposite side of the motorcycle.

**Caution:** It's extremely important to pay close attention to where you mount the lights and how you route the wires.

**Step Six:** Before operating the motorcycle,

turn the handlebars fully left, fully right, and fully compress the suspension. Confirm that the lights do not interfere with operation and that the wires have enough slack to account for all suspension and steering movement.